

Aviation Fabricators Inc.
805 North Fourth Street
Clinton, MO. 64735

ICA Document No.: AF-442
Revision (B)
Date: March 20, 2017
Page 1 of 13

**Aviation Fabricators Inc.
805 North Fourth Street
Clinton, MO. 64735**

INSTRUCTIONS FOR CONTINUED AIRWORTHINESS

For

2 Place Side Facing Divans

Document No.: AF-442

Revision "B"

Revision Date: 03/20/17

Applicable to:

**Piper models PA-31, PA-31-300, PA-31-325, PA-31-350,
PA-31P, PA-31P-350, PA-31T, PA-31T1, PA-31T2,
PA-31T3, PA-42, PA-42-720, PA-42-1000**

Modified by FAA STC SA1130SW

The information in the Instruction for Continued Airworthiness is FAA accepted material and complies with 14CFR 23.1529, Instructions for Continued Airworthiness. It supersedes or adds to that provided in the Maintenance Manual for the Piper PA-31 and PA-42 Series Aircraft, only where covered in the items contained herein. For limitations and procedures not contained in the Supplement, consult the Component Maintenance Manual, or other approved airplane data.

REVISION PAGE

Document Title: Instructions for Continued Airworthiness

Prepared By: Todd Pogue

Log of Revisions				
REV. NO.	EFFECTED PAGE(S)	DESCRIPTION	DATE	APPROVED BY
Orig. Issue	All	Initial Release	08/26/09	G.R. Lowe III
A	6, 11, & 12	*On page 6 added foot attachment view to Figure 1.0A *On pages 11 & 12 added the divan assembly removal and install procedures to "Typical Divan Service Instruction" in Section 9.0	09/09/09	G.R. Lowe III
B	11	*Updated drawer placard part numbers to 17-0671 & 17-0672 in Section 8.0, Note 1	03/20/17	Jeffrey R. Lowe

TABLE OF CONTENTS

DESCRIPTION	PAGE
INSTRUCTIONS FOR CONTINUED AIRWORTHINESS	1
REVISION PAGE	2
TABLE OF CONTENTS	3
1.0 INTRODUCTION.....	5
2.0 INSPECTION REQUIREMENTS AND OVERHAUL SCHEDULE.....	8
3.0 DIMENSION AND ACCESS:	10
4.0 LIFTING AND SHORING	10
5.0 LEVELING AND WEIGHING	10
6.0 TOWING AND TAXIING	10
7.0 PARKING AND MOORING.....	10
8.0 PLACARDS AND MARKINGS.....	11
9.0 SERVICE INFORMATION	11
10.0 AIRWORTHINESS LIMITATIONS	13

ABBREVIATIONS AND DEFINITIONS

Abbreviations	Definitions
AML	FAA Approved Model List (AML)
Detailed Inspection (DET)	An intensive examination of a specific item, installation or assembly to detect damage, failure or irregularity. Available lighting is normally supplemented with a direct source of good lighting at an intensity deemed appropriate. Inspection aids such as mirrors, magnifying lenses, etc. may be necessary. Surface cleaning and elaborate access procedures may be required.
FAA	Federal Aviation Administration
FAA MIDO	FAA Manufacturing Inspection District Office
General Visual Inspection (GVI)	A visual examination of an interior or exterior area, installation or assembly to detect obvious damage, failure or irregularity. This level of inspection is made from within touching distance unless otherwise specified. A mirror may be necessary to enhance visual access to all exposed surfaces in the inspection area. This level of inspection is made under normally available lighting conditions such as daylight, hanger lighting, flashlight or droplight and may require removal or opening of access panels or doors. Stands, ladders or platforms may be required to gain proximity to the area being checked.
ICA	Instructions for Continued Airworthiness
Special Detailed Inspection (SDI)	An intensive examination of a specific item, installation , or assembly to detect damage, failure or irregularity. The examination is likely to make extensive use of specialized Inspection Techniques and/or equipment. Intricate cleaning and substantial access or disassembly procedure may be required.
STC	Supplemental Type Certificate

1.0 INTRODUCTION

The purpose of this Maintenance Manual Supplement and Instructions for Continued Airworthiness (ICA) is to provide the maintenance technician with the information necessary to ensure the continued airworthiness of the Aviation Fabricators divan installation, per installation numbers 72-0154, 72-0173, and 72-0342, when installed in accordance with Aviation Fabricators design data included on Drawing List AF-206 and per Supplement Type Certificate (STC) SA1130SW.

Modifications to an aircraft obligates the operator to include the maintenance information provided by this document into the operators aircraft Maintenance Manual and operator's aircraft scheduled maintenance program. This document defines supplementary maintenance operations and frequencies recommended by Aviation Fabricators Inc., to ensure the aircraft's airworthiness.

The information contained herein addresses the requirements specified in 14 CFR 23.1529, Instructions for Continues Airworthiness and supplements the basic Airplane Maintenance Manual only in those areas listed as pertains to the installation of divan seats, as installed per the Aviation Fabricator Drawing List AF-206. For limitations and procedures not contained in this supplement, consult the basic Airplane Maintenance Manual.

DATA

All information to support the continued airworthiness of this modification is contained in:

STC SA1130SW.

STC drawing list: AF-206.

Installation: STC drawing list: AF-206:
Drawing D-10129 for p/n's 72-0173 and 72-0342
Drawing D-10133 for p/n 72-0154

Parts: Refer to 72-0154, 72-0173, and 72-0342 and respective drawings as listed on STC drawing list AF-206.

The divan is a self contained complete assembly that mounts to the existing seat track, using standard fittings, in accordance with approved floor plans.

Design Change Control

All data and changes to the parts and assemblies will be tracked per STC Drawing List AF-206 Rev J or later approved revision.

Applicable Aircraft

Piper PA-31, PA-31-300, PA-31-325, PA-31-350, PA-31P, PA-31P-350, PA-31T, PA-31T1, PA-31T2, PA-31T3, PA-42, PA-42-720, PA-42-1000 Aircraft

2 Place Divans

P/N's 72-0157, 72-0173 (shown), 72-0342

Top not shown for clarity

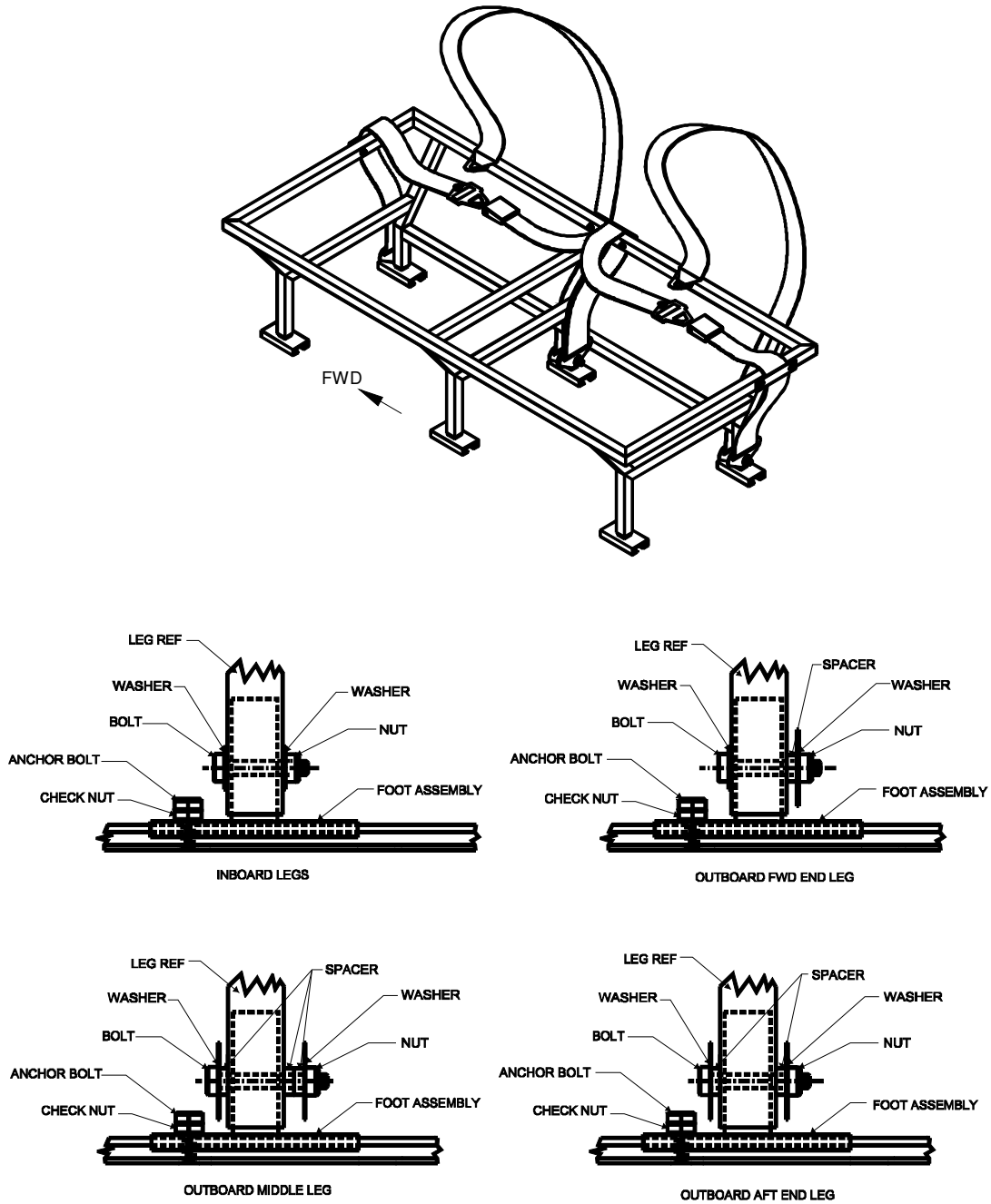

Figure 1.0A

Seat Belt Attachment

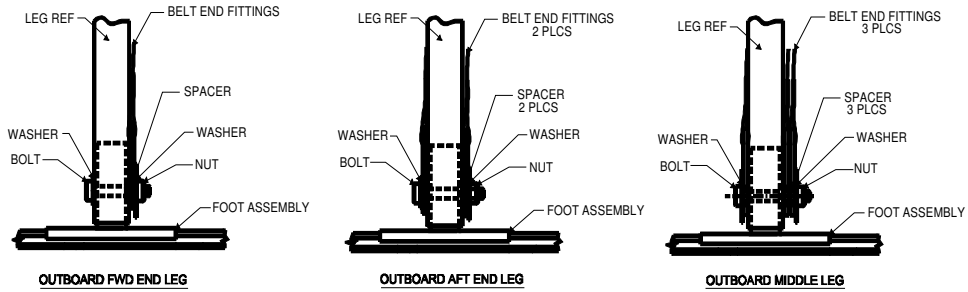

Figure 1.0B

Restraint Guides

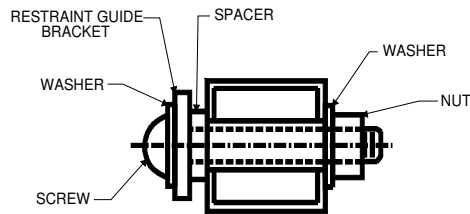

Figure 1.0C

Drawer Attachment

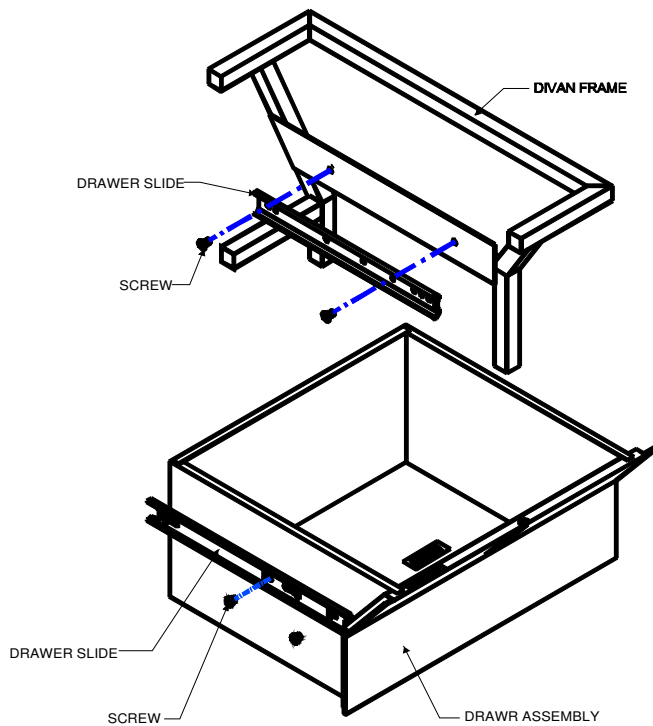

Figure 1.0D

2.0 INSPECTION REQUIREMENTS AND OVERHAUL SCHEDULE

1. To comply with 14 CFR 23.1529, continue the new divan and restraint system on the same inspection and maintenance schedule used per the applicable Piper PA-31 and PA-42 Series Maintenance Manual for seats.
 - a. The new divan and restraint systems require no service other than inspection at normal inspection interval of 100 hours or annually.
 - b. Perform a detailed visual inspection of each bottom and back cushion and cover to detect apparent or obvious defects, deterioration in the form of wear, tears, rips, punctures or irregularities that cause the cushion assembly to become worn or distorted. Replace the cushion assembly if this cover does not fit properly or the cushion develops a “lumpy” or irregular feel.
 - c. Perform a detailed visual inspection of each divan frame assembly including weld joints, diaphragm, fasteners and anchors, track fittings, and restraint systems to detect apparent or obvious defects, corrosion, cracks, large deformations (permanent deformation in frame tubes more than $\frac{1}{4}$ the overall thickness of the tube diameter), irregularities that cause the frame assembly and/or anchor/fitting to become distorted and not fit into the intended seat track/anchor locations.

2. Inspection Time Limit for 1, 2, 3, & 4 Place Side Facing Divan Assembly Installations:

100 hour or annual inspection for the divan and restraint systems

Task Code			Schedule	Date	Mech	Insp
AFI-100	a.	Inspect for damage to upholstery.				
AFI-101	b.	Inspect safety belts for wear, cuts, fraying, damage, and deterioration.				
AFI-102	c.	Inspect safety belt attachment fittings for wear and damage				
AFI-103	d.	Inspect foot fittings for damage, security, and function.				
AFI-104	e.	Inspect seat frame for damage, and corrosion.				
AFI-105	f.	Inspect overall seat for fit and function.				

A. The new divan and restraint system on the same inspection and maintenance schedule used per the applicable Piper Maintenance Manual for passenger seats.

3.0 DIMENSION AND ACCESS:

The installation of the divan seats does not change the dimensions of the aircraft or alter the access to any existing aircraft system.

4.0 LIFTING AND SHORING

No change.

5.0 LEVELING AND WEIGHING

No change.

6.0 TOWING AND TAXIING

No change.

7.0 PARKING AND MOORING

No change.

8.0 PLACARDS AND MARKINGS

1. If optional drawers are installed, placard part number's 17-0671 & 17-0672 must be installed at the top of the face of the drawer where visible when open or closed.

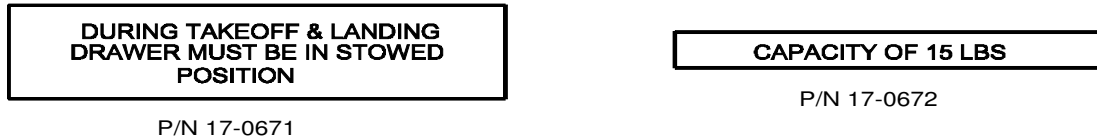

Figure 8.0A

9.0 SERVICE INFORMATION

Typical Divan Service Instructions:

A. Upholstery Cleaning:

Divan Service Instructions

1. Remove seat back and seat bottom cushion assemblies from sidewall and divan top.
2. If possible dry clean fabric cushions.
3. If dry cleaning is not possible clean fabric with Armour All fabric cleaner or equivalent.
4. Clean leather with Armour All leather cleaner or equivalent.
5. Clean drawer finish using Armour All multi-purpose cleaner or equivalent.
6. Clean and inspect restraint system for damage or excessive wear.
7. Inspect all attachment fittings and replace if necessary.
8. Inspect overall seat for fit and function.

Typical Divan Service Instructions:

Divan Assembly

The divans are self contained complete assemblies that mount to the existing aircraft cabin seat track using standard fittings in accordance with approved floor plans.

To remove the divan assembly from the foot fittings loosen the standard hardware at the bottom of the each leg and lift the divan from the foot assemblies. To remove the foot assemblies from the aircraft seat track loosen the anchor bolt and check nut on each foot and then slide the foot assembly to the end of the track.

To install the divan on to the existing seat track, first install the feet by locating them with the divan and tightening the anchor bolt and check nut through the foot into the existing holes in seat track so that the foot assembly will not move forward or aft. Then place the divan onto the feet by inserting each foot shaft into each leg, place the proper hardware through the holes in the leg and feet, and tighten divan into place. Refer to Figure 1.0A.

Cushions

Seat back and seat bottom cushion assemblies are removed by simply pulling the cushion inboard away from the Velcro on the sidewall or up away from the Velcro on the pan of the divan assembly, respectively.

Seat Belt and Shoulder Harness

Seat belt and Shoulder Harness removal is accomplished by loosening attaching hardware and removing from the divan frame assembly. Refer to Figure 1.0B and Figure 1.0C.

Drawers

Underseat drawers are removed from the divan by removing slide screws attached to the drawer sides. The drawer slides are removed from the divan by removing attaching screws. Figure 1.0D.

B. RECOMMENDED OVERHAUL PERIODS

No additional overhaul time limitations and requirements apply to the Aviation Fabricators 2 Place Side Facing Divans.

10.0 AIRWORTHINESS LIMITATIONS

The information contained herein supplements the basic Maintenance Manuals only in those areas listed, when the aircraft is modified in accordance with Aviation Fabricators Drawing List AF-206 Rev "J" or later approved revision. For limitations and procedures not contained in this supplement, consult the basic Airplane Maintenance Manuals.

The Airworthiness Limitations section is FAA approved and specifies maintenance required under Sec. 43.16 and 91.403 of the Federal Aviation Regulations unless an alternative program has been FAA approved.

AIRWORTHINESS LIMITATIONS - LOG OF REVISIONS			
REV.	EFFECTED PAGE (s)	DESCRIPTION of REVISION	DATE
(IR)	13	Initial Release	08/26/2009

AIRWORTHINESS LIMITATIONS

There are no Airworthiness Limitations to the aircraft with the addition of the 2 Place Side Facing Divan installed by this STC.

Distribution:

Per the requirement of Appendix G of 14 CFR Part 23 paragraph G23.1 (c), the changes made to the ICA by the applicant will be distributed via mail by means of paper copy.